

SCX 800A-3

HYDRAULIC CRAWLER CRANE

Specifications & Lifting Capacities

Hoist Rope 22.4mm

HITACHI SUMITOMO



Variation of The Attachment

Line Speed*	Front / Rear Winch (Rated with 7 t load)	m/min	105 (80)
	Third Winch (Rated with 7 t load)		90 (40)
Swing Speed		min ⁻¹ (rpm)	5.0
Travel Speed High / Low *		km/h	1.6 / 1.1 (Standard:Link shoes)
			1.8 / 1.2 (Optional:Flat shoes)
Gradeability		% (Degree)	30 (17)
Engine Model			Cummins QSB6.7
Engine Maximum Output		kW/min ⁻¹ (ps/rpm)	201 / 2000 (273 / 2000)

Note : Speeds marked with "*" may vary depending on load applied.

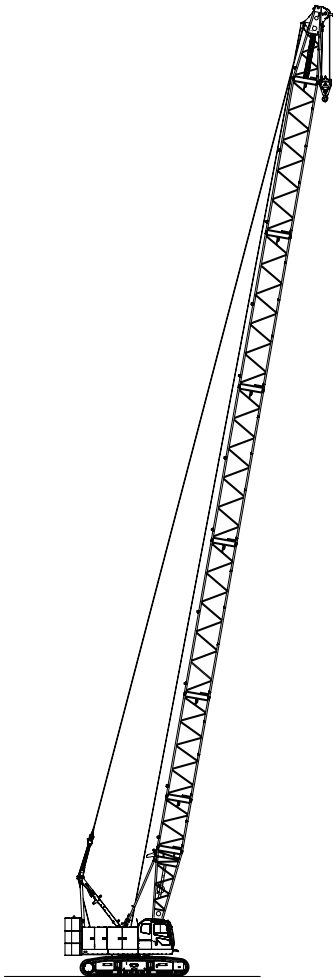

**Crane Specification
(Boom Longest Length)**

Boom Length	m	9.5 to 54.5
Ground Contact Pressure	kPa (kgf/cm ²)	91.1(0.93):Link shoes
		95.1(0.97):Flat shoes (Boom longest length with 20 t hook)
Overall Operating Weight	t	Approximately 80 (Boom longest length with 20 t hook)

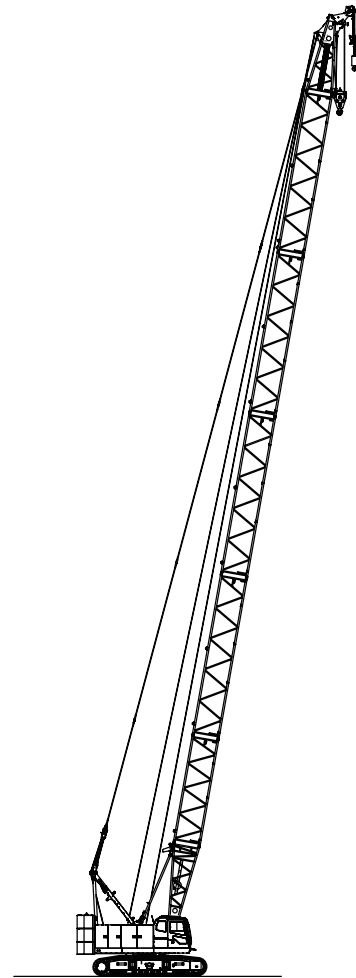

**Crane Specification
(Boom Longest Length with Aux. Sheave)**

Boom Length	m	12.5 to 51.5
Ground Contact Pressure	kPa (kgf/cm ²)	91.8(0.94):Link shoes
		95.8(0.98):Flat shoes (Boom longest length with 20t hook+ aux. sheave with 7 t hook attached)
Overall Operating Weight	t	Approximately 80 (Boom longest length with 20t hook + aux. sheave with 7 t hook attached)

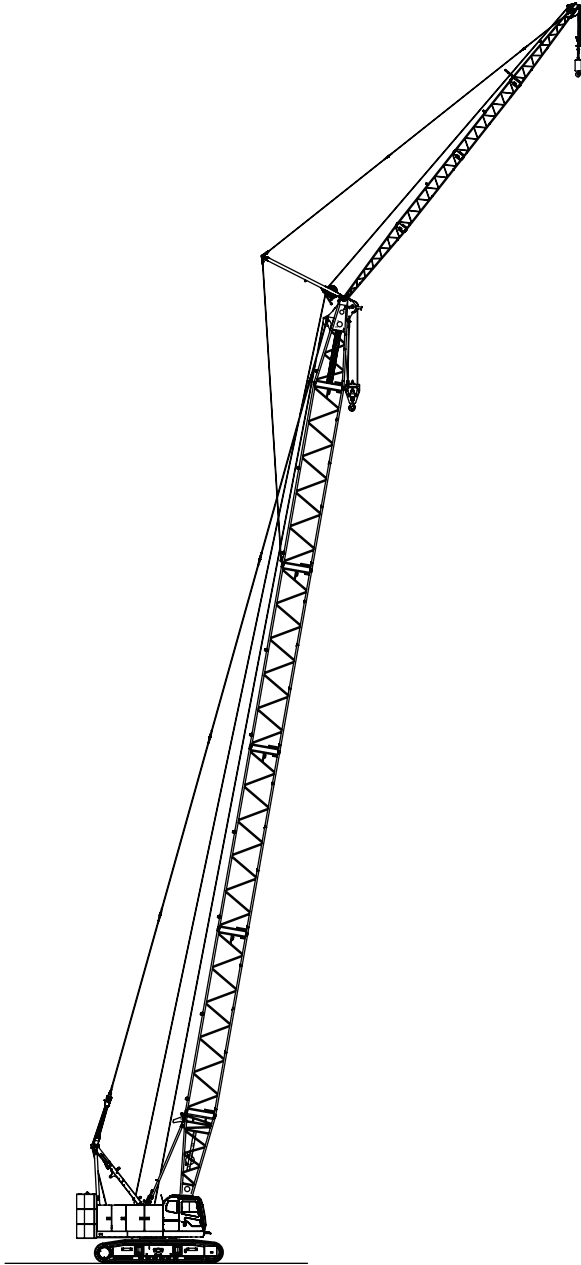

**Crane Specification
(Boom Longest Length with Crane Jib)**

Boom Length	m	27.5 to 45.5
Crane Jib Length	m	9 to 18
Boom + Crane Jib Longest Length	m	45.5 + 18
Ground Contact Pressure	kPa (kgf/cm ²)	92.1(0.94):Link shoes 96.0(0.98):Flat shoes (Boom + crane jib longest length with 20 t + 7 t hook attached)
Overall Operating Weight	t	Approximately 81 (Boom + crane jib longest length with 20 t + 7 t hook attached)

NOTE :
Illustration are when standard link shoes and non-cast type weights are installed.

VARIATION

Variation of The Attachment	2
------------------------------------	----------

SPECIFICATIONS

Specifications	6
-----------------------	----------

Crane Specifications	8
-----------------------------	----------

Dimensions and Specifications	8
--	----------

Boom and Crane Jib Configurations	9
--	----------

Combination of Boom and Crane Jib (Offset Angle 10° and 30°)	12
---	-----------

Working Ranges	13
-----------------------------	-----------

■ Main Boom	13
-------------------	----

■ Aux. Sheave	14
---------------------	----

■ 18 m Crane Jib (Offset Angle 10° and 30°)	15
---	----

Gross Rated Load Table	16
-------------------------------------	-----------

■ Main Boom (1/2)	16
-------------------------	----

■ Main Boom (2/2)	17
-------------------------	----

■ Aux. Sheave (1/2)	18
---------------------------	----

■ Aux. Sheave (2/2)	19
---------------------------	----

■ Main Boom with Aux. Sheave (1/2)	20
--	----

■ Main Boom with Aux. Sheave (2/2)	21
--	----

■ Crane Jib (1/4)	22
-------------------------	----

■ Crane Jib (2/4)	23
-------------------------	----

■ Crane Jib (3/4)	24
-------------------------	----

■ Crane Jib (4/4)	25
-------------------------	----

■ Main Boom with Crane Jib (1/4)	26
--	----

■ Main Boom with Crane Jib (2/4)	27
--	----

■ Main Boom with Crane Jib (3/4)	28
--	----

■ Main Boom with Crane Jib (4/4)	29
--	----

Clamshell Specifications	30
---------------------------------	-----------

Dimensions and Specifications	30
--	-----------

■ Working Ranges	30
------------------------	----

■ Specifications	31
------------------------	----

■ Clamshell Bucket.....	31
■ Gross Rated Load Table.....	31

TECHNICAL DATA

Weights and Dimensions of Disassembled Units	32
Weights and Dimensions List	32
Equipment List	37
Standard and Optional Equipment	37

Specifications

Engine

Model	Cummins QSB6.7
Type	4-cycle, Water-cooled, Direct injection, Turbo-charged, Diesel engine
Displacement	6.7 liters
Maximum Output	201 kW / 2,000 min ⁻¹ (273 ps / 2,000 rpm)
Fuel Tank Capacity	428 liters
Notes	Engine meets Stage IV / Tier 4f of engine exhaust gas emission regulations in USA, Europe, and Japan. Engine rated horsepower is based on international rating formula that includes engine alternator and without fan.

Control

Control System	Main actuators are actuated by main hydraulic system controlled with pilot hydraulic system. Safety devices are securely operated by combined various electronic control with hydraulic system. Working speed can be precisely controlled according to control lever stroke and control dials depending on work.
Control Levers	Designed and positioned based on ergonomics. Arm-chair lever type is standard. Cross operation lever type and front lever type are available as option.
Display Panel Design	8 inches size. Located to check work state easily without disturbing the view of the operator.

Hydraulic System

Hydraulic Oil Tank Capacity	320 liters		
Hydraulic Pump Capacity	Max.	31.4 MPa	
	P1	280 liters / min	for Front, Rear, boom hoist winch and travel
	P2	280 liters / min	for Front, Rear, third winch and travel
	P3	160 liters / min	for Swing, Crawler side frame retract and Gantry cyl.
	P4	41 liters / min	Pilot control, Brake cooling, Reeving tagline, etc.
	P5	41 liters / min	
	P6	41 liters / min	
P7	32 liters / min		

Winch

Front and Rear Winch				
Winch		Front	Rear	
Rope Diameter		22.4 mm	22.4 mm	
Rope Length	Standard	235 m	150 m	for Aux. sheave
	Winding Capacity	-	150 m	for Crane jib
Line Pull	Rated	69 kN	69 kN	
Standard Equipment		High-speed winching is possible by ECO winch mode with low engine speed under light loads.		
Optional Equipment		Free fall winch with brake controlled by pedal operation.		

Boom Hoist Winch

Rope Diameter	16 mm		
Rope Length	Incorporated	150 m	
Hydraulic motor with multi-disc brakes.			

Third Winch (Optional)

Rope Diameter	22.4 mm		
Rope Length	Standard	180 m	
	Winding Capacity	228 m	
Line Pull	Rated	69 kN	
Free fall winch with brake controlled by pedal operation.			

Swing System

Consisted of 1 hydraulic motors with reduction gear and multi-disc brakes and a swing bearing which has inner tooth. Optional swing brake pedal enables operator to control swing precisely.

Gantry

Gantry is welded steel construction. Raised and lowered by power hydraulic cylinders.

Counterweight

Upper Weight (Standard) : 3.4m width non cast	Total Weight	28.2 ton
	9.2 ton Base Weight (A)	1 piece
	9.5 ton Weight (B)	2 piece
Upper Weight (Optional) : 3.2m width cast	Total Weight	28.2 ton
	9.2 ton Base Weight (A)	1 piece
	9.1 ton Insert Weight (B)	1 piece
	9.9 ton Top Weight (C)	1 piece
Lower Weight : only for optional flat type crawler	Total Weight	4.0 ton
	2.0 ton Lower Weight	2 pieces

Carbody Frame

Welded steel construction with crawler side frame extend-retract cylinders.

Crawler Side frame

Link type (Standard)

Frame	Welded steel box construction, and can be retracted.	
Crawler Shoe	Link type 810 mm width shoes each side.	
Upper Roller	2 pieces double flange type for each side.	
Lower Roller	12 pieces each side.	
	Forging heat treated steel with double flange type. 2 plane bearing with floating seal for lifetime lubrication.	
Travel Device	1 peace each side.	
	Hydraulic travel device (Hydraulic motor and reducer)	
	Travel speed (Gradability : 30%)	High : 1.6 km/h Low : 1.1 km/h

Flat type (Optional)

Frame	Welded steel box construction, and can be retracted.	
Crawler Shoe	Flat type 800 mm width shoes each side.	
Upper Roller	2 pieces double flange type for each side.	
Lower Roller	10 pieces each side.	
	Forging heat treated steel with double flange type. 2 plane bearing with floating seal for lifetime lubrication.	
Travel Device	1 peace each side.	
	Hydraulic travel device (Hydraulic motor and reducer)	
	Travel speed (Gradability : 30%)	High : 1.8 km/h Low : 1.2 km/h

Crane Specifications

Dimensions and Specifications

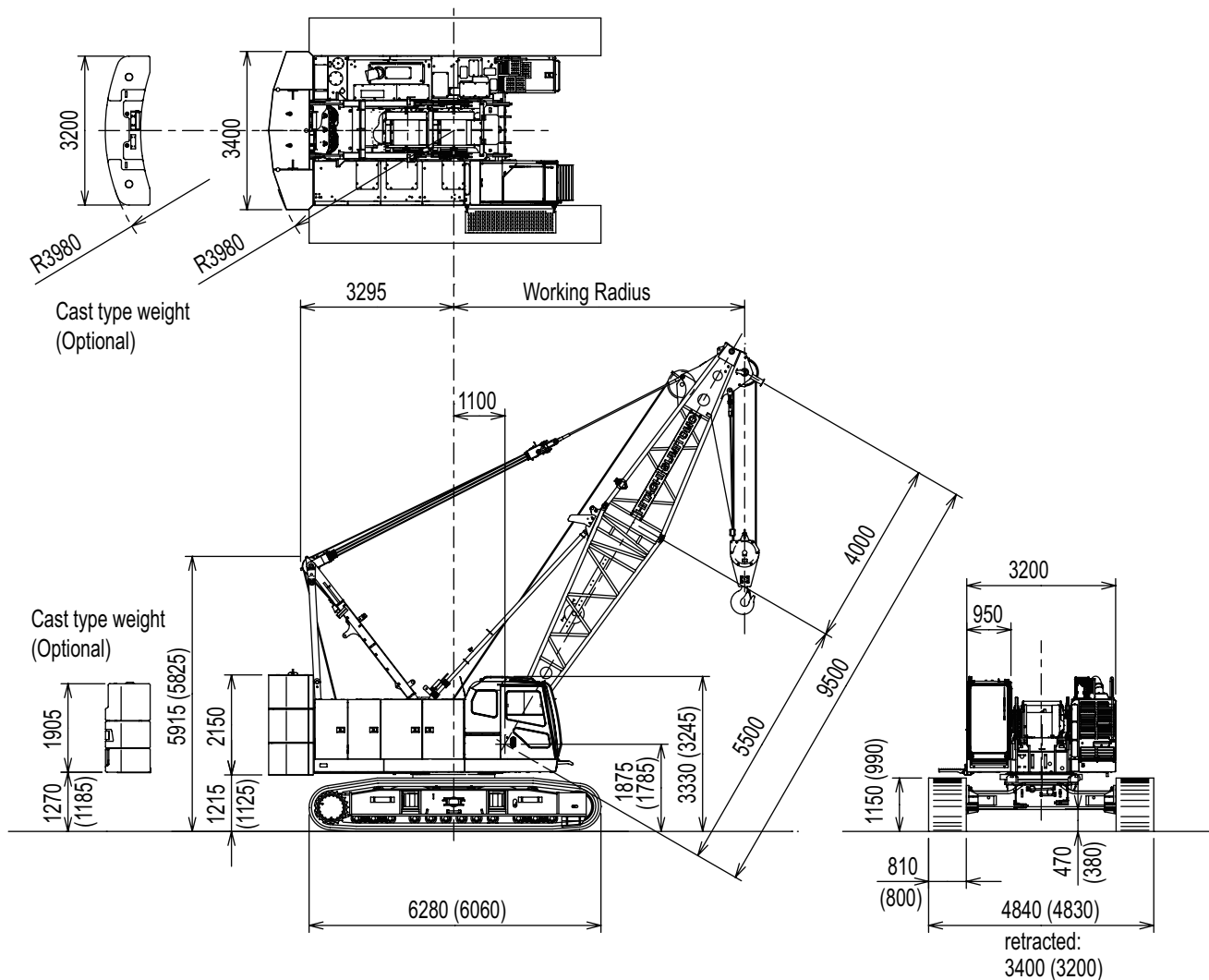

NOTE : () In case of the flat shoes.

Crane Specifications

Max. Lifting Load × Working Radius	t × m	80×3.3
Basic Boom Length	m	9.5
Max. Boom Length	m	54.5
Max. Crane Jib Length	m	9 to 18
Max. Boom + Jib Length	m	45.5 + 18
Ground Contact Pressure	kPa (kgf/cm ²)	86.5 (0.88) (w / Basic Boom, 80 t Hook, Link shoes)
		90.2 (0.92) (w / Basic Boom, 80 t Hook, Flat shoes)
Overall Operating Weight	t	Approximately 76 (w / Basic Boom, 80 t Hook)

NOTE : Data is expressed in SI units followed by conventional units in ().

Hook Weight

80 t	800 kg
40 t	520 kg
20 t	410 kg
7 t	260 kg

Boom and Crane Jib Configurations

Boom	
Boom Length (m)	Boom Configurations
9.5	
12.5	
15.5	☆
18.5	☆
21.5	☆
24.5	☆
27.5	☆
30.5	☆
33.5	☆

A star mark(☆) indicates manufacturer's recommended boom configuration.

Boom			
Boom Length (m)		Boom Configurations	
36.5	☆		
39.5	☆		
42.5	☆		
45.5	☆		
48.5	☆		
51.5	☆		
54.5			

A star mark(☆) indicates manufacturer's recommended boom configuration.

Aux. Sheave Installable Boom Length																
Boom Length (m)	9.5	12.5	15.5	18.5	21.5	24.5	27.5	30.5	33.5	36.5	39.5	42.5	45.5	48.5	51.5	54.5
With Aux. Sheave	×	○	○	○	○	○	○	○	○	○	○	○	○	○	○	×

(○ : Attachable × : Not Attachable)

Dimensions Not Shown In The Figure

Symbols	Boom Length (m)
3	3
6	6
9	9
9B	9

"9B" is for use with fly Jib. "9" is used instead of "9B".

Pendant Rope

Symbols	Length (m)	Rope Diameter (mm)	Imprint
3	3	32	□ • △ • 32 • 3 • C
3.2	3.215	32	□ • △ • 32 • 3.215 • C
6	6	32	□ • △ • 32 • 6 • C
9	9	32	□ • △ • 32 • 9 • C

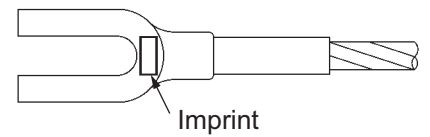

Check the pendant rope with referring to the imprints on the rope end.

Combination of Boom and Crane Jib (Offset Angle 10° and 30°)

Combination of Boom and Crane Jib (Offset Angle 10° and 30°)																
Boom Length (m)		9	12.5	15.5	18.5	21.5	24.5	27.5	30.5	33.5	36.5	39.5	42.5	45.5	48.5	51.5
Jib Length (m)	9	×	×	×	×	×	×	○	○	○	○	○	○	○	×	×
	13.5	×	×	×	×	×	×	○	○	○	○	○	○	○	×	×
	18	×	×	×	×	×	×	○	○	○	○	○	○	○	×	×

(○ : Attachable × : Not Attachable)

Crane Jib (Offset Angle 10° and 30°)		
Crane Jib Length (m)	Offset Angle	Crane Jib Configurations
9	10°	
	30°	
13.5	10°	
	30°	
18	10°	
	30°	

Dimensions Not Shown In The Figure

Symbols	Jib Length (m)
4.5	4.5

Jib Pendant Rope

Symbols	Length (m)	Rope Diameter (mm)	Imprint
2.9	2.85	20	□ · △ · 20 · 2.85 · C
8.5	8.45	20	□ · △ · 20 · 8.45 · C
18	18.35	20	□ · △ · 20 · 18.35 · C
30	29.5	20	□ · △ · 20 · 29.5 · C

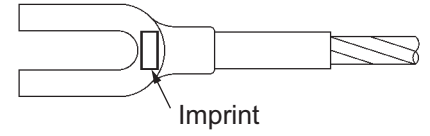

Check the pendant rope with referring to the imprints on the rope end.

Working Ranges

■ Main Boom

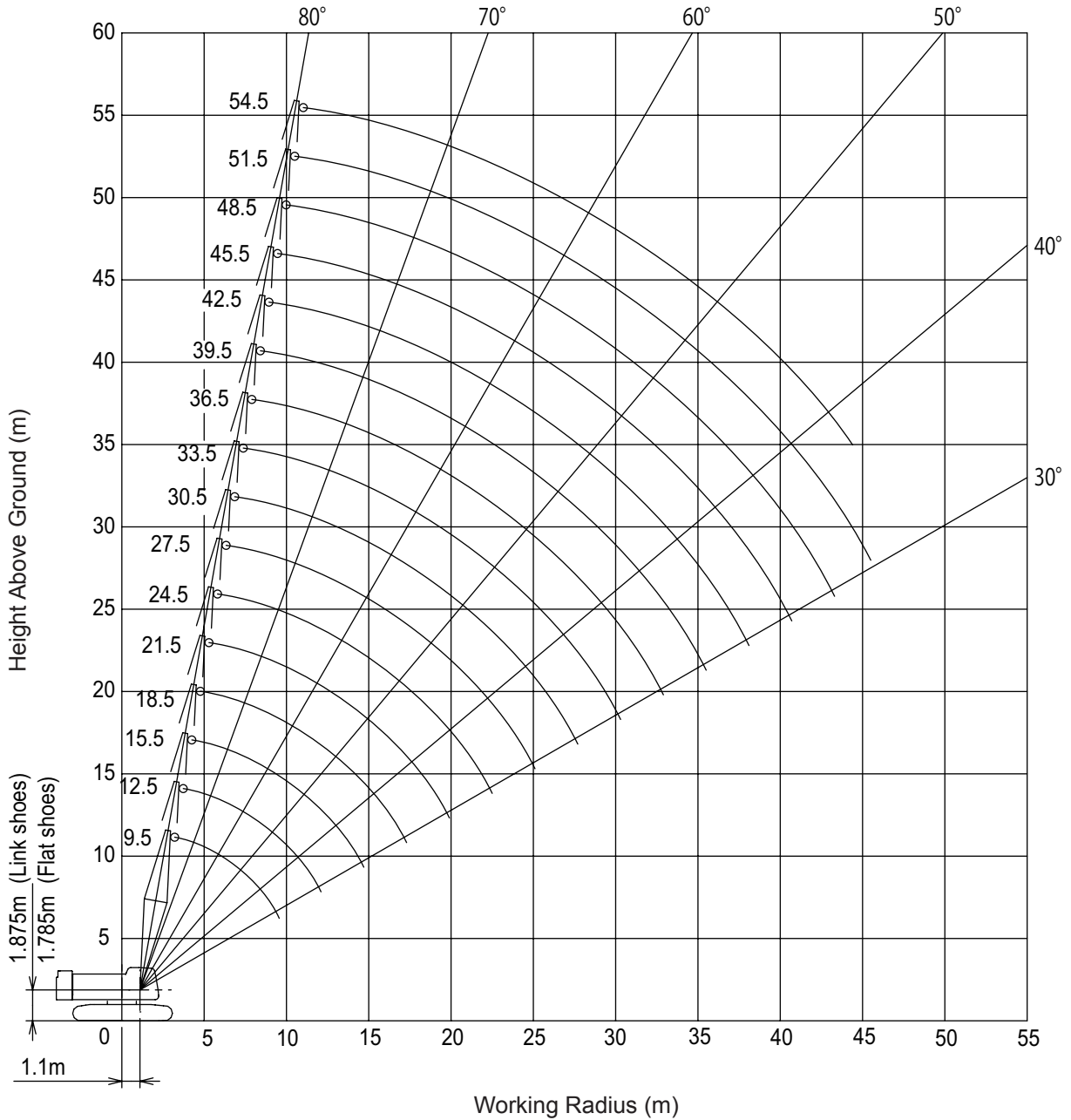
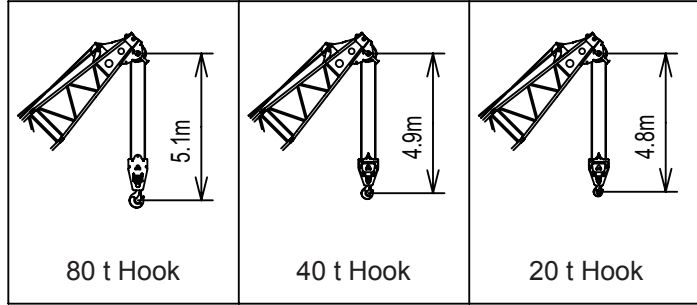

■ Aux. Sheave

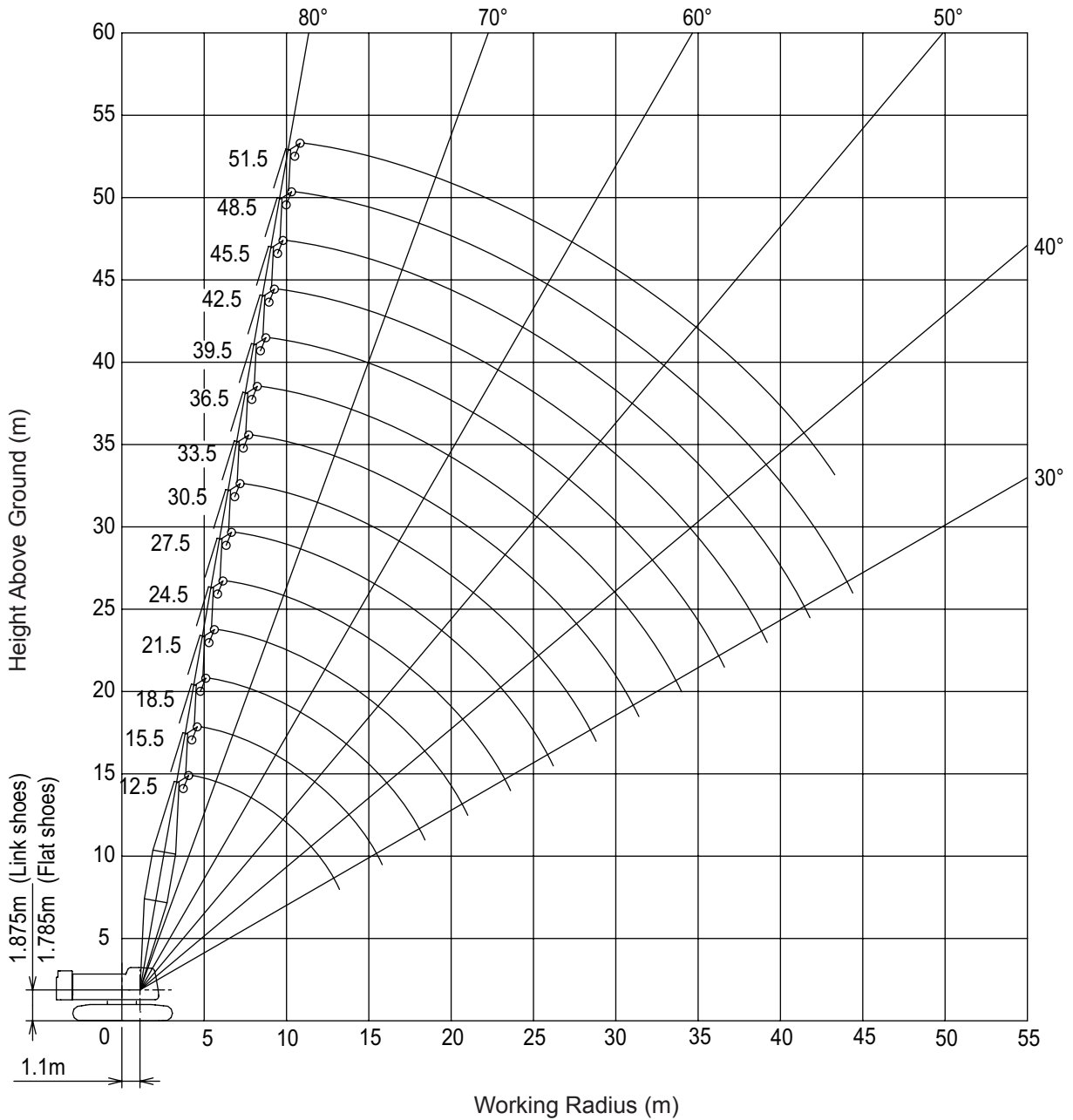
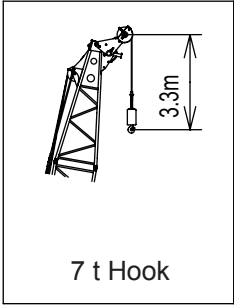

■ 18 m Crane Jib (Offset Angle 10° and 30°)

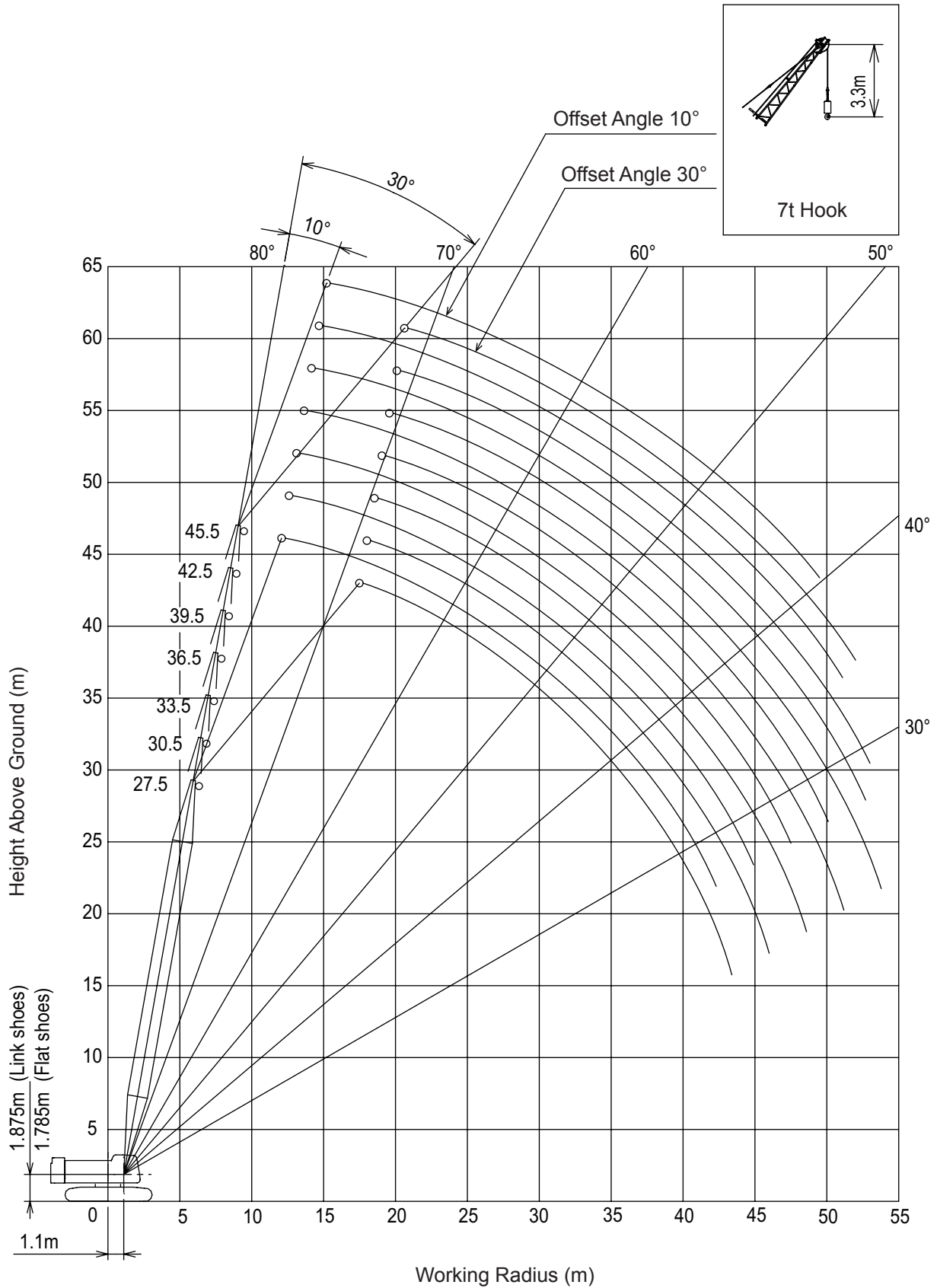

Gross Rated Load Table

■ Main Boom (1/2)



unit ; ton

Working Radius (m)	Boom Length (m)								Working Radius (m)
	9.5	12.5	15.5	18.5	21.5	24.5	27.5	30.5	
3.3	80.00	3.9mx							3.3
3.5	76.50	70.60t	4.4mx						3.5
4	70.00	69.50	63.30t						4
4.5	62.30	62.15	62.00						4.5
5	56.30	56.15	56.00	53.55					5
5.5	51.35	51.20	50.30	47.95	45.75	6.1mx	6.6mx		5.5
6	46.40	46.30	45.35	43.35	41.50	39.10t	34.60t	7.2mx	6
7	38.60	38.55	37.80	36.30	34.95	33.70	32.50	30.50t	7
8	31.90	31.85	31.75	31.20	30.10	29.15	28.20	27.30	8
9	27.15	27.05	26.95	26.90	26.40	25.60	24.85	24.10	9
10	9.5mx	23.50	23.35	23.30	23.20	22.80	22.15	21.50	10
12	25.25t	18.50	18.35	18.30	18.15	18.10	18.05	17.60	12
14		12.1mx	15.05	14.95	14.80	14.75	14.70	14.60	14
16		18.30t	14.7mx	12.55	12.45	12.35	12.30	12.15	16
18			14.10t	17.3mx	10.65	10.55	10.50	10.35	18
20				11.35t	19.9mx	9.20	9.10	8.95	20
22					9.35t	8.10	8.00	7.85	22
24						22.5mx	7.10	6.95	24
26						7.85t	25.1mx	6.20	26
28							6.65t	27.7mx	28
30								5.65t	30

1. The rated loads are determined according to EN13000 rating with the machine on firm level ground.
2. The figures surrounded by bold lines are based on factors other than those which would cause a tipping condition.
3. To calculate the maximum load that can actually be lifted, deduct weight of all lifting accessories, such as boom hook, from figures shown above.
4. Working radius is the horizontal distance from the slewing center to the center of gravity of a lifted load.
5. The counterweight is shown in the below table.

Crawler shoe	Upper weight	Lower weight
Link shoes	28.2	-
Flat shoes	28.2	4.0

6. The relations between the reeving part number of rope and the maximum rated loads is shown in the table next page.

■ Main Boom (2/2)



unit ; ton

Working Radius (m)	Boom Length (m)								Working Radius (m)
	33.5	36.5	39.5	42.5	45.5	48.5	51.5	54.5	
6	7.7mx								6
7	27.45t	8.3mx	8.8mx						7
8	26.40	24.70t	22.50t	9.4mx	9.9mx				8
9	23.35	22.70	22.00	20.50t	18.90t	10.4mx	11.0mx	11.5mx	9
10	20.85	20.35	19.75	19.25	18.70	17.40t	15.95t	13.75t	10
12	17.10	16.70	16.25	15.85	15.40	14.95	14.55	13.60	12
14	14.40	14.10	13.65	13.35	13.00	12.60	12.25	12.00	14
16	12.05	12.00	11.70	11.45	11.15	10.80	10.50	10.30	16
18	10.25	10.20	10.05	9.95	9.70	9.35	9.10	8.90	18
20	8.85	8.80	8.65	8.60	8.45	8.20	7.95	7.80	20
22	7.75	7.65	7.50	7.45	7.35	7.20	7.00	6.85	22
24	6.80	6.75	6.60	6.55	6.40	6.30	6.15	6.05	24
26	6.05	6.00	5.85	5.75	5.65	5.50	5.40	5.35	26
28	5.45	5.35	5.20	5.10	5.00	4.85	4.75	4.70	28
30	4.90	4.80	4.65	4.55	4.45	4.30	4.20	4.15	30
32	30.3mx	4.35	4.20	4.10	3.95	3.85	3.70	3.65	32
34	4.80t	32.9mx	3.75	3.65	3.55	3.40	3.30	3.25	34
36		4.15t	35.5mx	3.30	3.20	3.05	2.90	2.85	36
38			3.50t	3.00	2.85	2.70	2.60	2.55	38
40				38.1mx	2.60	2.45	2.30	2.25	40
42				2.95t	40.7mx	2.15	2.05	1.95	42
44					2.50t	43.3mx	1.80	1.75	44
46						2.00t	45.9mx	1.50	46
48							1.60t	1.30	48

■ The relations between the reeving part number of rope and the maximum rated loads

Hook Capacity (t)	Hook Weight (t)	Maximum rated loads (t)									
		10 falls	9 falls	8 falls	7 falls	6 falls	5 falls	4 falls	3 falls	2 falls	1 fall
80	0.80	80	63	56	49	42	35	28	21	14	-
40	0.52	-	-	-	-	40	35	28	21	14	-
20	0.41	-	-	-	-	-	-	-	20	14	-
7	0.26	-	-	-	-	-	-	-	-	-	7

■ Aux. Sheave (1/2)



unit ; ton

Working Radius (m)	Boom Length (m)							Working Radius (m)
	12.5	15.5	18.5	21.5	24.5	27.5	30.5	
4.7	7.00	5.2mx						4.7
5	7.00	7.00t	5.8mx					5
5.5	7.00	7.00	7.00t	6.3mx	6.9mx			5.5
6	7.00	7.00	7.00	7.00t	7.00t	7.4mx		6
7	7.00	7.00	7.00	7.00	7.00	7.00t		7
8	7.00	7.00	7.00	7.00	7.00	7.00	7.00	8
9	7.00	7.00	7.00	7.00	7.00	7.00	7.00	9
10	7.00	7.00	7.00	7.00	7.00	7.00	7.00	10
12	7.00	7.00	7.00	7.00	7.00	7.00	7.00	12
14	13.2mx	7.00	7.00	7.00	7.00	7.00	7.00	14
16	7.00t	15.8mx	7.00	7.00	7.00	7.00	7.00	16
18		7.00t	7.00	7.00	7.00	7.00	7.00	18
20			18.4mx	7.00	7.00	7.00	7.00	20
22			7.00t	21.0mx	7.00	7.00	7.00	22
24				7.00t	23.6mx	6.90	6.75	24
26					7.00t	6.15	6.00	26
28						26.2mx	5.35	28
30						6.10t	28.8mx	30
32							5.15t	32

1. The rated loads are determined according to EN13000 rating with the machine on firm level ground.
2. The figures surrounded by bold lines are based on factors other than those which would cause a tipping condition.
3. To calculate the maximum load that can actually be lifted, deduct weight of all lifting accessories, such as boom hook and jib hook, from figures shown above.
4. Working radius is the horizontal distance from the slewing center to the center of gravity of a lifted load.
5. The counterweight is shown in the below table.

Crawler shoe	Upper weight	Lower weight
Link shoes	28.2	-
Flat shoes	28.2	4.0

6. Hook weight are shown in the table next page.

■ Aux. Sheave (2/2)



unit ; ton

Working Radius (m)	Boom Length (m)							Working Radius (m)
	33.5	36.5	39.5	42.5	45.5	48.5	51.5	
7	8.5mx							7
8	7.00t	9.1mx	9.6mx					8
9	7.00	7.00t	7.00t	10.2mx	10.7mx	11.2mx	11.4mx	9
10	7.00	7.00	7.00	7.00t	7.00t	7.00t	7.00t	10
12	7.00	7.00	7.00	7.00	7.00	7.00	7.00	12
14	7.00	7.00	7.00	7.00	7.00	7.00	7.00	14
16	7.00	7.00	7.00	7.00	7.00	7.00	7.00	16
18	7.00	7.00	7.00	7.00	7.00	7.00	7.00	18
20	7.00	7.00	7.00	7.00	7.00	7.00	7.00	20
22	7.00	7.00	7.00	7.00	7.00	6.95	6.70	22
24	6.65	6.55	6.40	6.35	6.20	6.05	5.90	24
26	5.85	5.80	5.65	5.55	5.45	5.30	5.15	26
28	5.25	5.15	5.00	4.90	4.80	4.65	4.50	28
30	4.70	4.60	4.45	4.35	4.25	4.10	3.95	30
32	31.4mx	4.10	3.95	3.85	3.75	3.60	3.45	32
34	4.35t	3.70	3.55	3.45	3.30	3.15	3.05	34
36			3.20	3.10	2.95	2.80	2.65	36
38			36.6mx	2.75	2.65	2.50	2.35	38
40			3.10t	39.2mx	2.35	2.20	2.05	40
42				2.60t	41.8mx	1.95	1.80	42
44					2.10t	1.70	1.55	44
46						44.4mx	1.35	46
48						1.65t	46.5mx	48
50							1.30t	50

■ The hook weight

Hook Capacity (t)	Hook Weight (t)
80	0.80
40	0.52
20	0.41
7	0.26

■ Main Boom with Aux. Sheave (1/2)



unit ; ton

Working Radius (m)	Boom Length (m)							Working Radius (m)
	12.5	15.5	18.5	21.5	24.5	27.5	30.5	
3.9	70.60	4.4mx						3.9
4	69.35	63.10t						4
4.5	61.95	61.75						4.5
5	55.90	55.75	53.20					5
5.5	50.95	49.95	47.60	45.35	6.1mx	6.6mx		5.5
6	46.05	45.00	43.00	41.15	38.75t	34.25t	7.2mx	6
7	38.30	37.45	36.00	34.55	33.35	32.15	30.10t	7
8	31.60	31.50	30.85	29.75	28.75	27.85	26.90	8
9	26.80	26.70	26.65	26.05	25.25	24.45	23.70	9
10	23.25	23.10	23.05	22.95	22.45	21.80	21.15	10
12	18.25	18.10	18.00	17.90	17.85	17.75	17.25	12
14	12.1mx	14.80	14.70	14.55	14.50	14.40	14.30	14
16	18.05t	14.7mx	12.30	12.15	12.10	12.00	11.90	16
18		13.85t	17.3mx	10.40	10.30	10.20	10.10	18
20			11.10t	19.9mx	8.90	8.80	8.70	20
22				9.10t	7.85	7.70	7.60	22
24					22.5mx	6.80	6.65	24
26					7.60t	25.1mx	5.95	26
27						6.40t	27.7mx	27
28							5.40t	28

- The rated loads are determined according to EN13000 rating with the machine on firm level ground.
- The figures surrounded by bold lines are based on factors other than those which would cause a tipping condition.
- To calculate the maximum load that can actually be lifted, deduct weight of all lifting accessories, such as boom hook and jib hook, from figures shown above.
- Working radius is the horizontal distance from the slewing center to the center of gravity of a lifted load.
- The counterweight is shown in the below table.

Crawler shoe	Upper weight	Lower weight
Linkshoes	28.2	-
Flat shoes	28.2	4.0

- The relations between the reeving part number of rope and the maximum rated loads

■ Main Boom with Aux. Sheave (2/2)



unit ; ton

Working Radius (m)	Boom Length (m)							Working Radius (m)
	33.5	36.5	39.5	42.5	45.5	48.5	51.5	
6	7.7mx							6
7	27.10t	8.3mx	8.8mx					7
8	26.00	24.30t	22.10t	9.4mx	9.9mx			8
9	22.95	22.35	21.60	20.10t	18.45t	10.4mx	11.0mx	9
10	20.50	19.95	19.35	18.85	18.25	17.00t	15.50t	10
12	16.75	16.35	15.85	15.45	15.00	14.55	14.10	12
14	14.05	13.70	13.25	12.95	12.60	12.20	11.85	14
16	11.75	11.70	11.35	11.05	10.75	10.40	10.05	16
18	9.95	9.90	9.75	9.55	9.25	8.95	8.65	18
20	8.55	8.50	8.35	8.25	8.10	7.80	7.50	20
22	7.45	7.35	7.20	7.15	7.00	6.80	6.55	22
24	6.55	6.45	6.30	6.25	6.10	5.95	5.75	24
26	5.80	5.70	5.55	5.45	5.35	5.20	5.05	26
28	5.15	5.05	4.90	4.80	4.70	4.55	4.40	28
30	4.60	4.50	4.35	4.25	4.15	4.00	3.85	30
32	30.3mx	4.05	3.90	3.80	3.65	3.50	3.40	32
34	4.55t	32.9mx	3.50	3.40	3.25	3.10	2.95	34
36		3.85t	35.5mx	3.00	2.90	2.75	2.60	36
38			3.20t	2.70	2.55	2.40	2.25	38
40				38.1mx	2.30	2.15	2.00	40
42				2.70t	40.7mx	1.90	1.75	42
44					2.20t	43.3mx	1.50	44
46						1.75t	45.9mx	46
48							1.30t	48

■ The relations between the reeving part number of rope and the maximum rated loads

Hook Capacity (t)	Hook Weight (t)	Maximum rated loads (t)									
		10 falls	9 falls	8 falls	7 falls	6 falls	5 falls	4 falls	3 falls	2 falls	1 fall
80	0.80	80	63	56	49	42	35	28	21	14	-
40	0.52	-	-	-	-	40	35	28	21	14	-
20	0.41	-	-	-	-	-	-	-	20	14	-
7	0.26	-	-	-	-	-	-	-	-	-	7

■ Crane Jib (1/4)



Unit ; ton

Boom length (m)	27.5						30.5						Boom length (m)
Jib length (m)	9		13.5		18		9		13.5		18		Jib length (m)
Jib offset / Working radius (m)	10	30	10	30	10	30	10	30	10	30	10	30	Jib offset / Working radius (m)
9.6	7.00		11.2mx				10.2mx		11.8mx				9.6
10	7.00	12.3mx	7.00t		12.8mx		7.00t	12.9mx	7.00t		13.3mx		10
12	7.00	7.00t	7.00	15.3mx	7.00t		7.00	7.00t	7.00	15.8mx	7.00t		12
14	7.00	7.00	7.00	7.00t	7.00		7.00	7.00	7.00	7.00t	7.00		14
16	7.00	7.00	7.00	7.00	7.00	18.2mx	7.00	7.00	7.00	7.00	7.00	18.7mx	16
18	7.00	7.00	7.00	6.75	6.90	5.25t	7.00	7.00	7.00	6.85	6.95	5.20t	18
20	7.00	7.00	7.00	6.40	6.80	5.15	7.00	7.00	7.00	6.50	6.85	5.10	20
22	7.00	7.00	7.00	6.10	6.70	5.05	7.00	7.00	7.00	6.25	6.75	5.00	22
24	7.00	7.00	7.00	5.85	6.65	4.85	6.90	7.00	7.00	6.00	6.60	4.90	24
26	6.25	6.40	6.35	5.65	6.45	4.75	6.10	6.25	6.25	5.80	6.35	4.85	26
28	5.60	5.70	5.70	5.45	5.80	4.65	5.45	5.60	5.55	5.60	5.65	4.75	28
30	5.00	5.10	5.15	5.30	5.25	4.50	4.90	5.00	5.00	5.20	5.10	4.60	30
32	4.55	4.60	4.65	4.80	4.75	4.35	4.40	4.50	4.50	4.70	4.60	4.45	32
34	33.8mx	4.15	4.25	4.35	4.30	4.25	3.95	4.05	4.10	4.25	4.15	4.35	34
36	4.15t	34.4mx	3.85	3.95	3.95	4.10	3.60	3.65	3.70	3.85	3.80	4.00	36
38		4.10t	3.50	3.60	3.60	3.70	36.4mx	37.0mx	3.35	3.45	3.45	3.60	38
40				38.9mx	3.30	3.40	3.55t	3.50t	3.10	3.15	3.15	3.30	40
42				3.45t	3.05	3.10			40.6mx	41.5mx	2.90	3.00	42
44					42.3mx	43.4mx			3.00t	2.95t	2.65	2.70	44
46					3.00t	2.90t					44.9mx	45.9mx	46
48											2.55t	2.50t	48

1. The rated loads are determined according to EN13000 rating with the machine on firm level ground.
2. The figures surrounded by bold lines are based on factors other than those which would cause a tipping condition.
3. To calculate the maximum load that can actually be lifted, deduct weight of all lifting accessories, such as boom hook and jib hook, from figures shown above.
4. Working radius is the horizontal distance from the slewing center to the center of gravity of a lifted load.
5. The counterweight is shown in the below table.

Crawler shoe	Upper weight	Lower weight
Link shoes	28.2	-
Flat shoes	28.2	4.0

6. Hook weight are shown in the table next page.

■ Crane Jib (2/4)



Unit ; ton

Boom length (m)	33.5						36.5						Boom length (m)
	9		13.5		18		9		13.5		18		
Jib length (m)													Jib offset Working radius(m)
Jib offset Working radius(m)	10	30	10	30	10	30	10	30	10	30	10	30	
9	10.7mx						11.3mx						9
10	7.00t	13.4mx	12.3mx		13.9mx		7.00t		12.8mx				10
12	7.00	7.00t	7.00t		7.00t		7.00		7.00t		14.4mx		12
14	7.00	7.00	7.00	16.3mx	7.00		7.00	7.00	7.00	16.9mx	7.00t		14
16	7.00	7.00	7.00	7.00t	7.00	19.3mx	7.00	7.00	7.00	7.00t	7.00	19.8mx	16
18	7.00	7.00	7.00	6.90	7.00	5.15t	7.00	7.00	7.00	7.00	7.00	5.25t	18
20	7.00	7.00	7.00	6.60	6.90	5.15	7.00	7.00	7.00	6.70	6.95	5.25	20
22	7.00	7.00	7.00	6.35	6.80	5.00	7.00	7.00	7.00	6.45	6.85	5.10	22
24	6.75	6.95	6.90	6.10	6.65	4.90	6.65	6.90	6.80	6.20	6.80	4.95	24
26	5.95	6.15	6.10	5.90	6.20	4.85	5.85	6.10	6.00	6.00	6.15	4.85	26
28	5.30	5.45	5.45	5.70	5.55	4.75	5.20	5.40	5.35	5.65	5.45	4.80	28
30	4.75	4.90	4.85	5.10	4.95	4.65	4.65	4.80	4.75	5.05	4.90	4.70	30
32	4.25	4.35	4.35	4.55	4.45	4.55	4.15	4.30	4.30	4.50	4.40	4.65	32
34	3.85	3.90	3.95	4.10	4.05	4.30	3.75	3.85	3.85	4.05	3.95	4.20	34
36	3.45	3.55	3.55	3.70	3.65	3.90	3.35	3.45	3.45	3.65	3.55	3.80	36
38	3.15	3.20	3.25	3.35	3.30	3.50	3.00	3.10	3.15	3.25	3.20	3.45	38
40	39.0mx	39.6mx	2.95	3.05	3.00	3.20	2.75	2.80	2.85	2.95	2.90	3.10	40
42	3.00t	2.95t	2.65	2.75	2.75	2.90	41.6mx	2.50	2.55	2.65	2.65	2.80	42
44			43.2mx	2.50	2.50	2.60	2.50t	42.1mx	2.30	2.40	2.40	2.55	44
46			2.55t		2.30	2.35		2.50t	45.8mx	2.15	2.15	2.30	46
48					47.5mx	2.15			2.10t	46.6mx	1.95	2.05	48
50					2.15t	48.5mx				2.10t	1.80	1.85	50
52						2.10t					50.1mx	51.1mx	52
54											1.75t	1.75t	54

■ The hook weight

Hook Capacity (t)	Hook Weight (t)
80	0.80
40	0.52
20	0.41
7	0.26

■ Crane Jib (3/4)



Unit ; ton

Boom length (m)	39.5						42.5						Boom length (m)	
	9		13.5		18		9		13.5		18			Jib length (m)
	Jib offset	Working radius(m)	Jib offset	Working radius(m)	Jib offset	Working radius(m)	Jib offset	Working radius(m)	Jib offset	Working radius(m)	Jib offset	Working radius(m)		
9	11.8mx												9	
10	7.00t		13.4mx				12.4mx		13.9mx				10	
12	7.00	14.5mx	7.00t		15.0mx		7.00t	15.0mx	7.00t		15.5mx		12	
14	7.00	7.00t	7.00	17.4mx	7.00t		7.00	7.00t	7.00		7.00t		14	
16	7.00	7.00	7.00	7.00t	7.00		7.00	7.00	7.00		7.00		16	
18	7.00	7.00	7.00	7.00	7.00	20.3mx	7.00	7.00	7.00	7.00	7.00	20.9mx	18	
20	7.00	7.00	7.00	6.80	6.95	5.15t	7.00	7.00	7.00	6.90	7.00	5.15t	20	
22	7.00	7.00	7.00	6.55	6.85	5.10	7.00	7.00	7.00	6.65	6.90	5.10	22	
24	6.50	6.75	6.65	6.30	6.65	5.00	6.40	6.70	6.45	6.40	6.50	5.00	24	
26	5.70	5.95	5.85	6.10	5.95	4.95	5.65	5.90	5.80	6.15	5.80	4.90	26	
28	5.05	5.25	5.20	5.50	5.30	4.90	4.95	5.20	5.10	5.45	5.20	4.85	28	
30	4.50	4.65	4.65	4.90	4.75	4.80	4.40	4.60	4.55	4.85	4.65	4.75	30	
32	4.00	4.15	4.15	4.40	4.25	4.60	3.90	4.05	4.05	4.30	4.15	4.50	32	
34	3.55	3.70	3.70	3.90	3.80	4.10	3.45	3.60	3.60	3.85	3.70	4.05	34	
36	3.20	3.30	3.30	3.50	3.40	3.70	3.10	3.20	3.20	3.45	3.30	3.60	36	
38	2.85	2.95	3.00	3.15	3.05	3.30	2.75	2.85	2.85	3.05	2.95	3.25	38	
40	2.55	2.65	2.65	2.80	2.75	3.00	2.45	2.55	2.55	2.75	2.65	2.90	40	
42	2.30	2.35	2.40	2.55	2.50	2.70	2.20	2.25	2.30	2.45	2.40	2.60	42	
44	2.05	2.10	2.15	2.25	2.25	2.40	1.95	2.00	2.05	2.20	2.15	2.35	44	
46	44.2mx	44.7mx	1.95	2.00	2.00	2.15	1.75	1.80	1.85	1.95	1.90	2.10	46	
48	2.05t	2.05t	1.75	1.80	1.80	1.95	46.8mx	47.3mx	1.65	1.70	1.70	1.85	48	
50			48.4mx	49.2mx	1.65	1.75	1.65t	1.65t	1.45	1.50	1.50	1.65	50	
52			1.70t	1.70t	1.45	1.55			51.0mx	51.8mx	1.35	1.45	52	
54					52.6mx	53.7mx			1.35t	1.35t	52.7mx	53.5mx	54	
56					1.40t	1.40t					1.30t	1.30t	56	

1. The rated loads are determined according to EN13000 rating with the machine on firm level ground.
2. The figures surrounded by bold lines are based on factors other than those which would cause a tipping condition.
3. To calculate the maximum load that can actually be lifted, deduct weight of all lifting accessories, such as boom hook and jib hook, from figures shown above.
4. Working radius is the horizontal distance from the slewing center to the center of gravity of a lifted load.
5. The counterweight is shown in the below table.

Crawler shoe	Upper weight	Lower weight
Link shoes	28.2	-
Flat shoes	28.2	4.0

6. Hook weight are shown in the table next page.

■ Crane Jib (4/4)



Unit ; ton

Boom length (m)	45.5						Boom length (m)
Jib length (m)	9		13.5		18		Jib length (m)
Jib offset Working radius(m)	10	30	10	30	10	30	Jib offset Working radius(m)
10	12.9mx						10
12	7.00t	15.6mx	14.5mx				12
14	7.00	7.00t	7.00t				14
16	7.00	7.00	7.00				16
18	7.00	7.00	7.00		7.00		18
20	7.00	7.00	7.00	6.95	7.00		20
22	7.00	7.00	7.00	6.70	6.95	5.15	22
24	6.20	6.50	6.25	6.50	6.25	5.05	24
26	5.50	5.80	5.55	6.00	5.60	4.95	26
28	4.85	5.10	4.95	5.35	5.00	4.85	28
30	4.25	4.50	4.40	4.75	4.50	4.80	30
32	3.75	3.95	3.90	4.20	4.00	4.40	32
34	3.35	3.50	3.45	3.75	3.60	3.95	34
36	2.95	3.10	3.10	3.30	3.20	3.50	36
38	2.65	2.75	2.75	2.95	2.85	3.15	38
40	2.35	2.45	2.45	2.65	2.55	2.80	40
42	2.05	2.15	2.15	2.35	2.25	2.50	42
44	1.80	1.90	1.90	2.05	2.00	2.25	44
46	1.60	1.65	1.70	1.80	1.80	2.00	46
48	1.40	1.45	1.50	1.60	1.55	1.75	48
50	48.9mx	49.4mx	1.30	1.40	1.40	1.55	50
52	1.30t	1.30t		51.0mx	51.0mx	1.35	52
54				1.30t	1.30t	52.5mx	54
56						1.30t	56

■ The hook weight

Hook Capacity (t)	Hook Weight (t)
80	0.80
40	0.52
20	0.41
7	0.26

■ Main Boom with Crane Jib (1/4)



Unit ; ton

Boom length (m)	27.5						30.5						Boom length (m)
	9		13.5		18		9		13.5		18		
Jib length (m)													Jib offset / Working radius (m)
Jib offset / Working radius (m)	10	30	10	30	10	30	10	30	10	30	10	30	
6.6	33.45	33.20	33.05	32.60	32.55	31.95	7.2mx	7.2mx	7.2mx	7.2mx	7.2mx	7.2mx	6.6
7	31.35	31.15	30.95	30.55	30.50	29.90	29.35t	29.10t	28.95t	28.55t	28.50t	27.95t	7
8	27.05	26.85	26.65	26.30	26.20	25.70	26.15	25.95	25.75	25.45	25.35	24.85	8
9	23.65	23.50	23.30	23.00	22.85	22.45	22.95	22.75	22.55	22.25	22.15	21.70	9
10	21.00	20.85	20.60	20.35	20.20	19.80	20.35	20.20	20.00	19.75	19.60	19.20	10
12	16.95	16.85	16.60	16.40	16.15	15.90	16.45	16.35	16.10	15.90	15.70	15.40	12
14	13.70	13.60	13.35	13.20	13.00	12.80	13.60	13.50	13.30	13.15	12.95	12.70	14
16	11.30	11.20	11.00	10.85	10.65	10.45	11.20	11.10	10.90	10.75	10.55	10.35	16
18	9.50	9.45	9.20	9.10	8.85	8.75	9.40	9.35	9.10	9.00	8.80	8.65	18
20	8.10	8.05	7.80	7.75	7.50	7.40	8.00	7.95	7.70	7.65	7.40	7.30	20
22	7.00	7.00	6.70	6.65	6.40	6.35	6.90	6.85	6.60	6.55	6.30	6.20	22
24	6.10	6.10	5.85	5.80	5.50	5.50	6.00	5.95	5.70	5.65	5.40	5.35	24
26	25.1mx	25.1mx	25.1mx	25.1mx	25.1mx	25.1mx	5.25	5.20	4.95	4.95	4.65	4.65	26
28	5.70t	5.70t	5.40t	5.40t	5.10t	5.10t	27.7mx	27.7mx	27.7mx	27.7mx	27.7mx	27.7mx	28
30							4.70t	4.70t	4.45t	4.40t	4.15t	4.15t	30

1. The rated loads are determined according to EN13000 rating with the machine on firm level ground.
2. To calculate the maximum load that can actually be lifted, deduct weight of all lifting accessories, such as boom hook and jib hook, from figures shown above.
3. Working radius is the horizontal distance from the slewing center to the center of gravity of a lifted load.
4. The counterweight is shown in the below table.

Crawler shoe	Upper weight	Lower weight
Link shoes	28.2	-
Flat shoes	28.2	4.0

5. The relations between the reeving part number of rope and the maximum rated loads is shown in the table next page.

■ Main Boom with Crane Jib (2/4)



Unit ; ton

Boom length (m)	33.5						36.5						Boom length (m)
	9		13.5		18		9		13.5		18		
Jib length (m)													Jib offset Working radius(m)
Jib offset Working radius(m)	10	30	10	30	10	30	10	30	10	30	10	30	
6	7.7mx	7.7mx	7.7mx	7.7mx	7.7mx	7.7mx							6
7	26.30t	26.10t	25.95t	25.60t	25.55t	25.00t	8.3mx	8.3mx	8.3mx	8.3mx	8.3mx	8.3mx	7
8	25.25	25.05	24.90	24.55	24.50	24.00	23.55t	23.35t	23.20t	22.90t	22.80t	22.35t	8
9	22.20	22.00	21.85	21.55	21.45	21.00	21.55	21.40	21.20	20.95	20.85	20.40	9
10	19.70	19.55	19.35	19.10	18.95	18.60	19.20	19.05	18.85	18.60	18.45	18.10	10
12	15.95	15.85	15.60	15.40	15.25	14.95	15.55	15.45	15.25	15.05	14.85	14.55	12
14	13.25	13.15	12.90	12.75	12.55	12.30	12.95	12.85	12.60	12.45	12.25	12.00	14
16	11.10	11.00	10.80	10.65	10.45	10.25	10.95	10.85	10.60	10.50	10.25	10.05	16
18	9.30	9.20	9.00	8.90	8.70	8.50	9.20	9.15	8.95	8.80	8.65	8.45	18
20	7.90	7.85	7.60	7.50	7.30	7.15	7.80	7.75	7.55	7.45	7.25	7.10	20
22	6.75	6.70	6.50	6.40	6.20	6.10	6.70	6.65	6.45	6.35	6.15	6.00	22
24	5.85	5.80	5.60	5.55	5.30	5.20	5.80	5.75	5.50	5.45	5.25	5.15	24
26	5.10	5.10	4.85	4.80	4.55	4.50	5.05	5.00	4.75	4.70	4.50	4.40	26
28	4.50	4.45	4.20	4.20	3.95	3.90	4.40	4.35	4.15	4.10	3.85	3.80	28
30	3.95	3.95	3.70	3.70	3.40	3.40	3.85	3.85	3.60	3.55	3.30	3.30	30
32	30.3mx	30.3mx	30.3mx	30.3mx	30.3mx	30.3mx	3.40	3.40	3.15	3.15	2.85	2.85	32
34	3.85t	3.85t	3.60t	3.60t	3.35t	3.35t	32.9mx	32.9mx	32.9mx	32.9mx	32.9mx	32.9mx	34
36							3.20t	3.20t	2.95t	2.95t	2.70t	2.70t	36

■ The relations between the reeving part number of rope and the maximum rated loads

Hook Capacity (t)	Hook Weight (t)	Maximum rated loads (t)				
		5 falls	4 falls	3 falls	2 falls	1 fall
80	0.80	35	28	21	14	-
40	0.52	35	28	21	14	-
20	0.41	-	-	20	14	-
7	0.26	-	-	-	-	7

■ Main Boom with Crane Jib (3/4)



Unit ; ton

Boom length (m)	39.5						42.5						Boom length (m)
	9		13.5		18		9		13.5		18		
Jib length (m)													Jib offset Working radius(m)
Jib offset Working radius(m)	10	30	10	30	10	30	10	30	10	30	10	30	
7	8.8mx	8.8mx	8.8mx	8.8mx	8.8mx	8.8mx							7
8	21.40t	21.20t	21.05t	20.75t	20.65t	20.20t	9.4mx	9.4mx	9.4mx	9.4mx	9.4mx	9.4mx	8
9	20.85	20.70	20.50	20.25	20.15	19.70	19.35t	19.20t	19.00t	18.75t	18.65t	18.25t	9
10	18.60	18.45	18.25	18.00	17.85	17.50	18.10	17.95	17.75	17.50	17.40	17.00	10
12	15.10	14.95	14.75	14.55	14.40	14.10	14.70	14.55	14.40	14.15	14.05	13.70	12
14	12.50	12.40	12.20	12.05	11.85	11.60	12.20	12.10	11.90	11.75	11.55	11.30	14
16	10.55	10.50	10.25	10.10	9.90	9.70	10.30	10.25	10.00	9.85	9.65	9.45	16
18	9.05	8.95	8.75	8.60	8.40	8.25	8.80	8.75	8.50	8.40	8.20	8.00	18
20	7.70	7.60	7.40	7.30	7.10	6.95	7.60	7.55	7.30	7.20	7.00	6.85	20
22	6.55	6.50	6.30	6.20	6.00	5.90	6.50	6.45	6.25	6.15	5.95	5.80	22
24	5.65	5.60	5.40	5.30	5.10	5.00	5.55	5.50	5.30	5.25	5.05	4.90	24
26	4.90	4.85	4.60	4.55	4.35	4.25	4.80	4.75	4.55	4.50	4.30	4.20	26
28	4.25	4.20	4.00	3.95	3.70	3.65	4.15	4.15	3.90	3.85	3.65	3.55	28
30	3.70	3.70	3.45	3.40	3.20	3.15	3.60	3.60	3.35	3.30	3.10	3.05	30
32	3.25	3.20	3.00	2.95	2.70	2.70	3.15	3.10	2.90	2.85	2.65	2.60	32
34	2.85	2.80	2.60	2.55	2.30	2.30	2.75	2.70	2.50	2.45	2.25	2.20	34
36	35.5mx	35.5mx	35.5mx	35.5mx	35.5mx	35.5mx	2.35	2.35	2.15	2.10	1.85	1.85	36
38	2.55t	2.55t	2.30t	2.30t	2.05t	2.05t	2.05	2.05	1.80	1.80	1.55	1.55	38
40							38.1mx	38.1mx	38.1mx	38.1mx	38.1mx	38.1mx	40
42							2.05t	2.05t	1.80t	1.80t	1.55t	1.55t	42

- The rated loads are determined according to EN13000 rating with the machine on firm level ground.
- To calculate the maximum load that can actually be lifted, deduct weight of all lifting accessories, such as boom hook and jib hook, from figures shown above.
- Working radius is the horizontal distance from the slewing center to the center of gravity of a lifted load.
- The counterweight is shown in the below table.

Crawler shoe	Upper weight	Lower weight
Link shoes	28.2	-
Flat shoes	28.2	4.0

- The relations between the reeving part number of rope and the maximum rated loads is shown in the table next page.

■ Main Boom with Crane Jib (4/4)



Unit ; ton

Boom length (m)	45.5						Boom length (m)
Jib length (m)	9		13.5		18		Jib length (m)
Jib offset Working radius(m)	10	30	10	30	10	30	Jib offset Working radius(m)
8	9.9mx	9.9mx	9.9mx	9.9mx	9.9mx	9.9mx	8
9	17.75t	17.60t	17.40t	17.15t	17.05t	16.65t	9
10	17.55	17.4	17.20	17.0	16.85	16.5	10
12	14.25	14.15	13.95	13.75	13.60	13.30	12
14	11.85	11.75	11.55	11.35	11.20	10.95	14
16	10.00	9.90	9.70	9.55	9.35	9.15	16
18	8.50	8.45	8.25	8.10	7.90	7.70	18
20	7.35	7.25	7.05	6.95	6.75	6.55	20
22	6.35	6.30	6.05	5.95	5.75	5.60	22
24	5.45	5.40	5.20	5.10	4.95	4.80	24
26	4.70	4.65	4.45	4.35	4.15	4.05	26
28	4.05	4.00	3.80	3.75	3.55	3.45	28
30	3.50	3.45	3.25	3.20	3.00	2.90	30
32	3.00	3.00	2.75	2.75	2.50	2.45	32
34	2.60	2.60	2.35	2.35	2.10	2.05	34
36	2.25	2.25	2.00	2.00	1.75	1.70	36
38	1.90	1.90	1.70	1.70	1.45	1.40	38
40	1.65	1.65	1.40	1.40	39.0mx	38.8mx	40
42	40.7mx	40.7mx	40.7mx	40.7mx	1.30t	1.30t	42
44	1.55t	1.55t	1.30t	1.30t			44

■ The relations between the reeving part number of rope and the maximum rated loads

Hook Capacity (t)	Hook Weight (t)	Maximum rated loads (t)				
		5 falls	4 falls	3 falls	2 falls	1 fall
80	0.80	35	28	21	14	-
40	0.52	35	28	21	14	-
20	0.41	-	-	20	14	-
7	0.26	-	-	-	-	7

Clamshell Specifications

Dimensions and Specifications

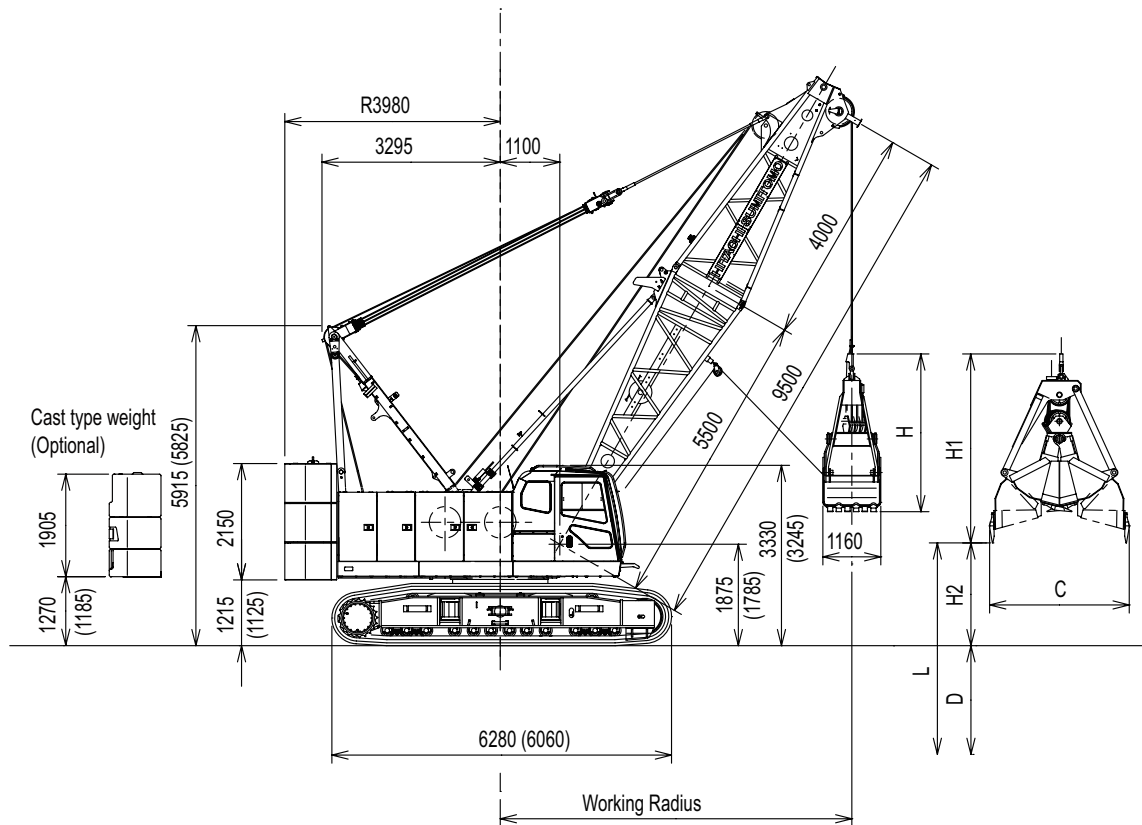

NOTE : () In case of the flat shoes.

Working Ranges

Boom Length	m	9.5				12.5				15.5			
Boom Angle	°	35	45	55	65	35	45	55	65	35	45	55	65
Working Radius	m	9.3	8.3	7.1	5.8	11.8	10.5	8.8	7.1	14.3	12.6	10.6	8.4
Gross Rated Load	t	6.5	6.5	6.5	6.5	6.5	6.5	6.5	6.5	6.5	6.5	6.5	6.5
Lift L (D + H2)	m	37.4	38.7	39.8	40.7	39.1	40.9	42.3	43.4	40.8	43.0	44.7	46.1
Max. Digging Depth D	m	36											
Bucket Dumping Height H2	m	1.4	2.7	3.8	4.7	3.1	4.9	6.3	7.4	4.8	7.0	8.7	10.1

Boom Length	m	18.5				21.5			
Boom Angle	°	35	45	55	65	35	45	55	65
Working Radius	m	16.7	14.7	12.3	9.6	19.2	16.8	14.0	10.9
Gross Rated Load	t	6.5	6.5	6.5	6.5	6.5	6.5	6.5	6.5
Lift L (D + H2)	m	42.5	45.1	47.2	48.9	44.2	47.2	49.7	51.7
Max. Digging Depth D	m	36							
Bucket Dumping Height H2	m	6.5	9.1	11.2	12.9	8.2	11.2	13.7	15.7

■ Specifications

Clamshell Specifications			
Bucket Capacity	m ³	1.2	
Allowed Maximum Gross Weight for Clamshell Bucket and Captured Load Combined	t	6.5	
Boom Length	m	9.5 to 21.5	
Maximum Digging Depth	m	36	
Support Wire Rope Speed *	m/min	105	Wire Rope Diameter 22.4 mm
Opening/Closing Wire Rope Speed *	m/min	105	
Boom Hoist Drum Wire Rope Speed (Raise) *	m/min	67	Wire Rope Diameter 16.0 mm
Boom Hoist Drum Wire Rope Speed (Lower) *	m/min	67	
Ground Contact Pressure	kPa (kgf/cm ²)	90.9 (0.93) (w/ Basic Boom, 1.2 m ³ Clamshell Bucket, Link shoes)	
		94.9 (0.97) (w/ Basic Boom, 1.2 m ³ Clamshell Bucket, Flat shoes)	
Overall Operating Weight	t	Approximately 76 (w/ Basic Boom, 1.2 m ³ Clamshell Bucket)	

NOTE :

- Speeds marked with "*" may vary depending on load applied.
- SI units are used for specifications. In parenthesis, conventional units are also indicated.
- Specifications other than those shown above are the same as those shown in the crane specifications section.

■ Clamshell Bucket

Capacity (m ³)	Weight (t)	C (mm)	H (mm)	H1 (mm)
1.2	3.1	2,600	3,100	3,700

■ Gross Rated Load Table

unit ; ton

Working Radius (m)	Boom Length (m)				
	9.5	12.5	15.5	18.5	21.5
5.8	6.5				
6.0	6.5	7.1mx			
7.0	6.5	6.5t	8.4mx		
8.0	6.5	6.5	6.5t	9.6mx	
9.0	6.5	6.5	6.5	6.5t	10.9mx
10.0	9.3mx	6.5	6.5	6.5	6.5t
12.0	6.5t	11.8mx	6.5	6.5	6.5
14.0		6.5t	6.5	6.5	6.5
16.0			14.3mx	6.5	6.5
18.0			6.5t	16.7mx	6.5
20.0				6.5t	19.2mx
22.0					6.5t

1. Max. clamshell rating is 6.5 t.
2. Mass of bucket plus load should not exceed clamshell ratings shown above. Following data are for a general digging application buckets.
Bucket Capacity 1.2 m³
Bucket Mass 3.1 t
3. In case of clamshell application, a 9.5 m boom is recommended as minimum length of boom, and max. boom length shall not exceed 21.5 m.
4. Apparent specific gravity of lifting material :
Earth 1.7 to 1.8 t/m³
Gravel 1.8 to 2.0 t/m³
5. The counterweight is shown in the next table.

Crawler shoe	Upper weight	Lower weight
Link shoe	28.2	-
Flat shoe	28.2	4.0

6. Max. digging depth below ground shall be 36 m.

Weights and Dimensions of Disassembled Units

Weights and Dimensions List

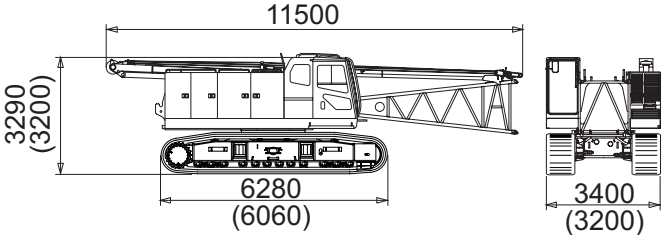
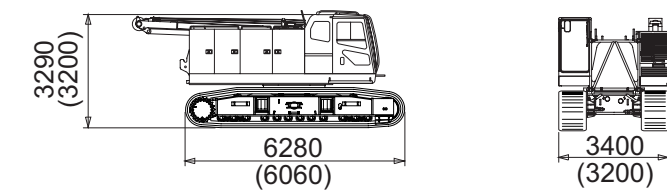
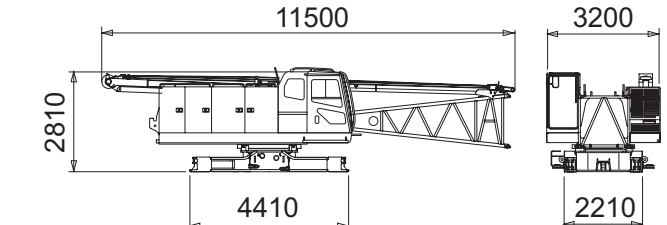
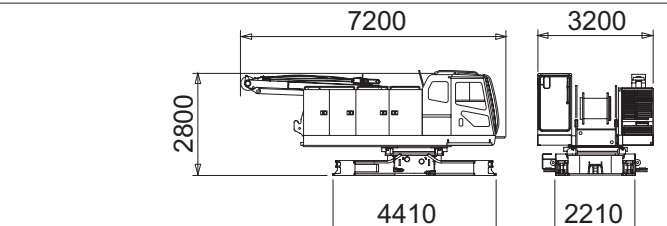
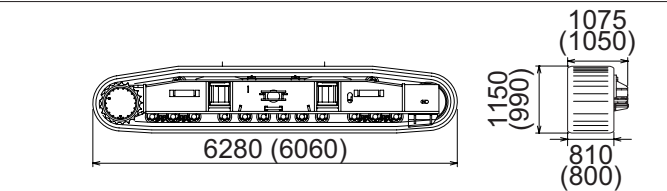

Weights and Dimensions of Disassembled Units

Description	Qty	Dimensions (mm)	Weight (kg)
Machinery With boom base With front winch wire rope With boom hoist drum wire rope With crawler With upper spreader With lower weight	1	 <p>NOTE : () In case of the flat shoes.</p>	45600 (45800)
Machinery With front winch wire rope With boom hoist drum wire rope With crawler With upper spreader With lower weight	1	 <p>NOTE : () In case of the flat shoes.</p>	44400 (44600)
Machinery With boom base With front winch wire rope With boom hoist drum wire rope With upper spreader	1		26700
Machinery With front winch wire rope With boom hoist drum wire rope With upper spreader	1		25500
Crawler side frame (ASSY)	2	 <p>NOTE : () In case of the flat shoes.</p>	8400 × 2 (7600 × 2)

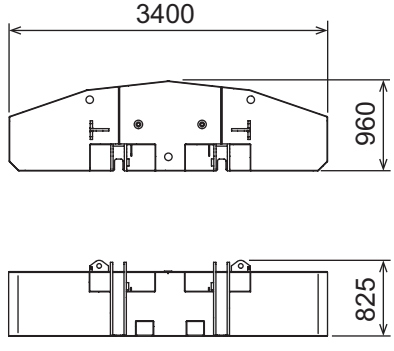
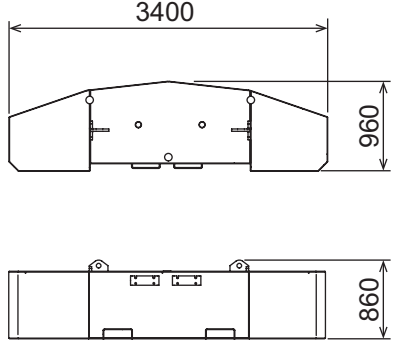
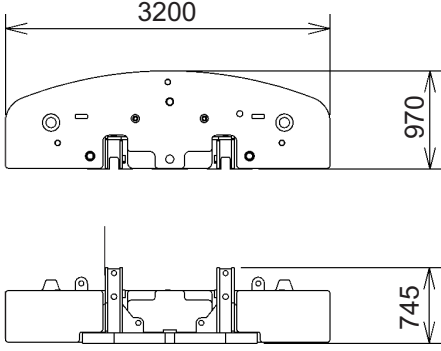
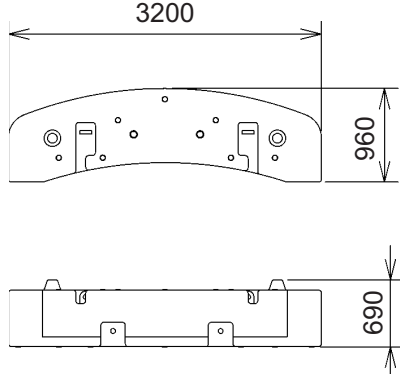
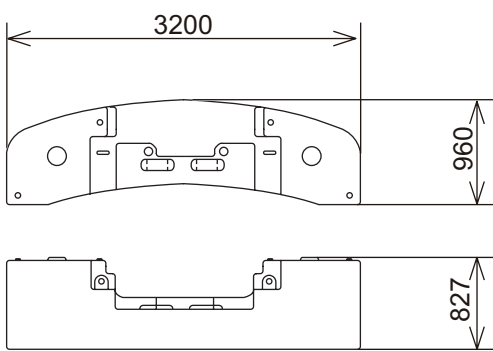
Weights and Dimensions of Disassembled Units

Description	Qty	Dimensions (mm)	Weight (kg)
Counter weight (A):Standard	1		9200
Counter weight (B):Standard	2		9500 × 2
Counter weight (A):Optional	1		9200
Counter weight (B):Optional	1		9100
Counter weight (C):Optional	1		9900

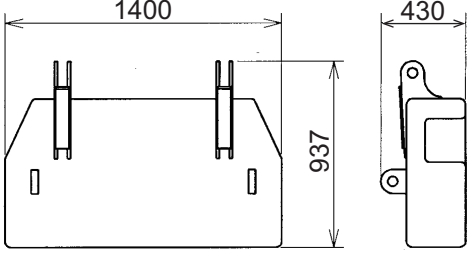
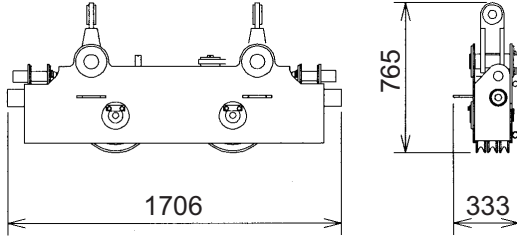
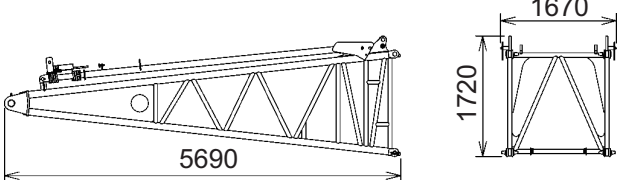
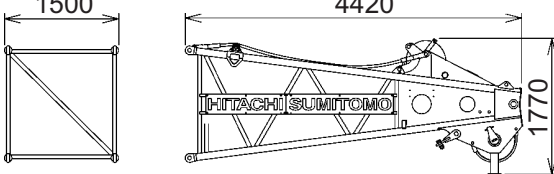
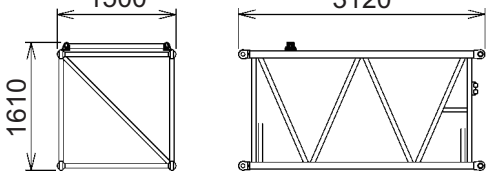
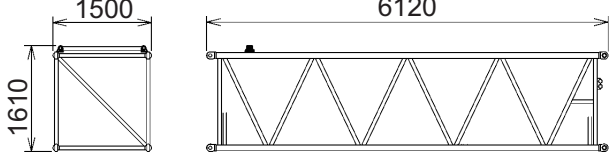
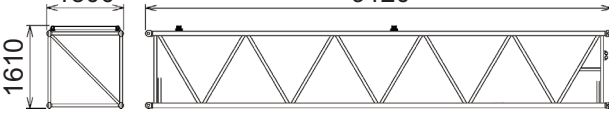
Weights and Dimensions of Disassembled Units

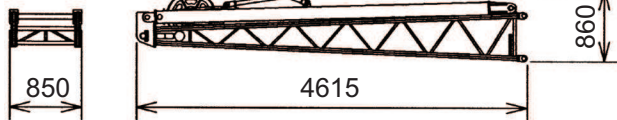
Description	Qty	Dimensions (mm)	Weight (kg)
Lower weight : In case of the flat shoes	2		2020
Upper spreader	1		285
Boom base (5.5) With connector pin With exclusive crane backstop	1 4 2		1230
Boom top (4) With pendant rope	1 2		1020
3 m boom insert (3) With connector pin Without pendant rope	1 4		325
6 m boom insert (6) With connector pin Without pendant rope	1 4		545
9 m boom insert (9) With connector pin Without pendant rope	1 4		750
9 m special boom insert (9B) (tower combined use boom) With connector pin Without pendant rope	1 4		755
Crane jib bottom (4.5) With connector pin With jib strut	1		490

Weights and Dimensions of Disassembled Units

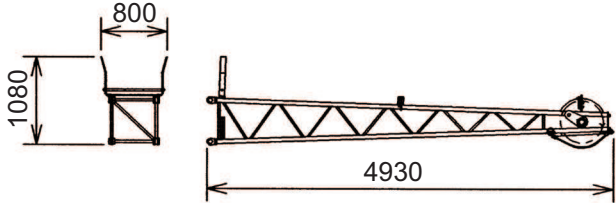
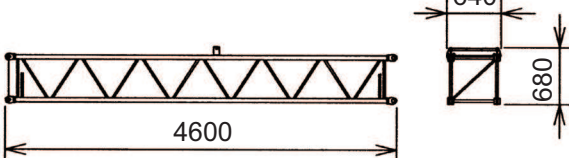
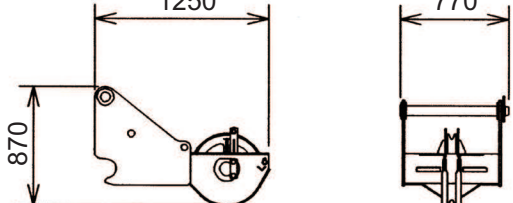
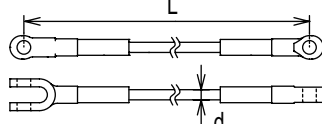
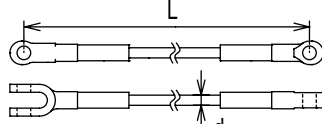
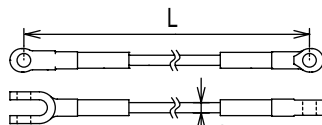
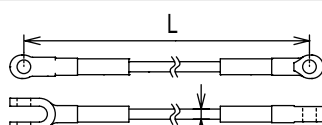
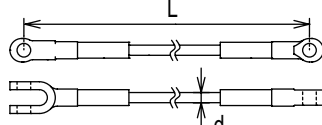
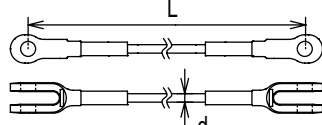
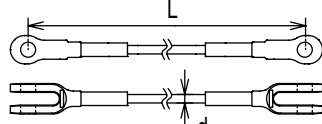
Description	Qty	Dimensions (mm)	Weight (kg)
Crane jib top (4.5) without pendant rope	1		290
4.5 m jib insert (4.5) With connector pin without pendant rope	1		140
Short jib With connector pin	1		250
Pendant Rope (3) connect pin	1		L=3000 d=32 25
Pendant Rope (6) connect pin	1		L=6000 d=32 40
Pendant Rope (9) connect pin	1		L=9000 d=32 55
Jib Pendant Rope (2.9) connect pin	1		L=2850 d=20 15
Jib Pendant Rope (8.5) connect pin	1		L=8450 d=20 25
Jib Pendant Rope (18) connect pin	1		L=18350 d=20 45
Jib Pendant Rope (30) connect pin	1		L=29500 d=20 65

Weights and Dimensions of Disassembled Units

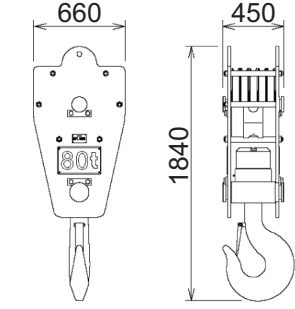
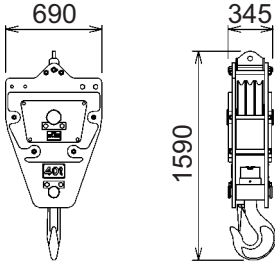
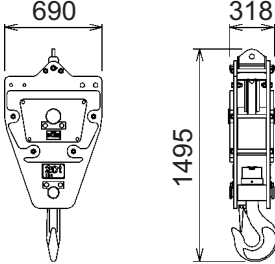
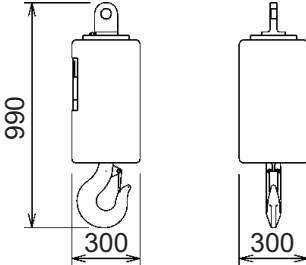
Description	Qty	Dimensions (mm)	Weight (kg)
80 t hook	1		800
40 t hook	1		520
20t hook	1		410
7t hook	1		260

Equipment List

Standard and Optional Equipment

○ : Standard ● : Optional – : No setting

Item		Crane	Clamshell
* are described in the last page of this list.			
Lower Structure	810 mm Crawler Shoe (Link shoes)	○	○
	800 mm Crawler Shoe (Flat shoes)	●	●
	Jack Up Unit	●	●
	Crawler Extension / Retraction System	○	○
	Up/Down Steps	○	○
	Shoe Tension Unit	○ ^{*1}	○ ^{*1}
Upper Structure	Cab Up / Down Catwalk	○	○
	Upper House Handrails (for Catwalk)	○	○
	Under Cover (Bed Lower Surface)	○	○
	Working Light (× 2)	○	○
	Back Mirror (Left / Right)	○	○
	Gantry Cylinders	○	○
	Central Lubrication Unit (for Turntable Bearing)	○	○
	Drum Flange Cover	○	○
	Auto Idle Stop	○	○
	Eco Winch	○	○
	Drum Mirror	●	●
	Drum Light	●	●
	Winch Rope Retainer (Front Winch)	●	●
	Winch Rope Retainer (Rear Winch)	●	●
	Catwalk (Folding Type, Left / Right)	● / ○ ^{*2}	● / ○ ^{*2}
	3400mm Width Counter Weight (Non-Cast Type)	○	○
	3200mm Width Counter Weight (Cast Type)	●	●
	Electric Fuel Pump	●	●
	Upper House Handrails (Folding Type)	● / ○ ^{*2}	● / ○ ^{*2}
	Winch with Front and Rear Free Mechanism	●	●
Third Winch (Rope not Included)	●	-	
Cab	Air Conditioner	○	○
	Sunvisor	○	○
	Sunshade	○	○
	Wiper with Washer (Front Window, Cab Roof Window)	○	○
	Microphone & Loud-speaker	●	●
	AM / FM Radio (with Clock)	○	○
	Room Lamp	○	○
	Cup Holder	○	○
	24 V Power Socket (× 2)	○	○
	Floor Carpet	○	○
	Level Gauge (in Cab)	○	○
	Accelerator Pedal (Right Side)	●	●
	Arm Chair Lever	○	○
	Cross Operation Lever (Lever Lock not Attached)	● / ○ ^{*2}	● / ○ ^{*2}
	Front Operation Lever (with Lever Lock)	●	●
	Seat without Suspension	○	○
	Seat with Suspension	● / ○ ^{*2}	● / ○ ^{*2}
	Travel Operation Pedal (Cannot be installed when winch with free mechanism attached)	●	●
	Boom Hoist Operation Pedal ^{*3}	●	●
	Swing Brake Operation Pedal ^{*3}	●	●

○ : Standard ● : Optional – : No setting

Item		Crane	Clamshell	
* are described in the last page of this list.				
Cab	Fan	●	●	
	Front / Rear Operation Lever, Brake Pedal Permutation	●	●	
	Fuel Burning Heater	●	●	
	Accelerator Grip	○	○	
	Drum Rotation Sensor (Front / Rear / Boom Hoist) ^{*4}	○	○	
	Speed Control Dial (Front / Rear/Boom Hoist / Swing)	○	○	
	Life Hanmer	○	○	
Attachment	9.5 m Basic Boom (Boom Base: 5.5 m, Top: 4 m)	○	○	
	3 m Boom Insert	●	●	
	6 m Boom Insert	●	●	
	9 m Boom Insert	●	●	
	9 m Special Boom Insert	●	-	
	Parts Set for 9 m Crane Jib [9 m Basic Jib, Anti-two Block, Jib Mast]	●	-	
	4.5 m Crane Jib Insert	●	-	
	Parts Set for Auxiliary Sheave [Auxiliary Sheave, Auxiliary Sheave Anti-two Block]	●	-	
	80 t Hook (5 Sheaves)	●	-	
	40 t Hook (3 Sheaves)	●	-	
	20 t Hook (1 Sheave)	●	-	
	7 t Hook	●	-	
Wire Rope	Front Winch (φ 22.4)	Mono Rope EP 3XF (40)	○	-
		IWRC 6 X Fi (25)	-	○ ^{*5}
	Rear Winch (φ 22.4)	Mono Rope EP 3XF (40)	●	-
		IWRC 6 X Fi (25)	-	○ ^{*6}
	Third Winch (φ 22.4)	XP IWRC6XWS(31)	●	-
Boom Hoist Winch (φ 16)	IWRC 6 X P · WS (31)	○	○	
Safety Device	Moment Limiter	○	○	
	3 Color Percentage Indicator Light	●	●	
	Gate Lock Lever	○	○	
	Individual Operation Lever Lock (Front, Rear, Boom Hoist, Travel) ^{*7}	○	○	
	Automatic Drum Lock (Boom Hoist)	○	○	
	Winch Drum Lock (Front/Rear)	○	○	
	Winch Drum Dead Turns Detective Device	○ ^{*8}	○ ^{*8}	
	Swing Lock	○	○	
	Swing Alarm	○	○	
	Travel Alarm	○	○	
	Auto Slowdown (Slow Stop)	○	○	
	Boom Hoist Limiting Device	○	○	
	Secondary Boom Over Hoist Prevent Device	○	○	
	Warning Alarm	○	○	
	Monitor Panel (Machine Monitoring)	○	○	
	Engine Start Interlock System	○	○	
	Emergency Engine Stop Switch (In cab)	○	○	
	Lifting Height Indication Device	○	○	
	Anti-two Block Device	○	-	
	Moment Limiter (M/L) Mode Selector (In Left House)	● / ○ ^{*8}	○	
	Swing Newtral Brake	○	○	
	Swing Restriction Unit	●	●	
	Lowering Limiter	●	●	
Anemometer	●	-		
Obstacle Lights (Fixed lights)	●	-		
Drum and Rear View Monitor System (3 Cameras)	●	●		
Cab Roof Window Guard	●	●		

○ : Standard ● : Optional – : No setting

Item		Crane	Clamshell
* are described in the last page of this list.			
Common Parts	Boom Back Stop	○	○
	Boom Angle Sensor	○	○
	Boom Lifting Piece	●	●
	Counter Weight with Self Assembly Unit ^{*9}	●	●
	Remote Sensing(Mobile Communication Terminal and Data Logging Device)	○	○
	Remote Sensing(Satellite Communication Terminal and Data Logging Device)	●	●
	Skywalk (with Stanchion)	●	-
	Skywalk (without Stanchion)	●	-
	Boom Top Under Surface Buffer (Protector)	●	●
	Load Table Sign (Whiteboard, Boom Base Installation)	●	●
	Insertable Company Name Plate (Both Side Surfaces of the Machine)	● ^{*10}	●
	Opening / Closing / Support Rope Stopper	-	○
	Hyd. Tagline (6 × Fi (29) ϕ 10 mm × 45 m)	● ^{*11}	○
	Reeving Winch (4 × F (30) ϕ 8 mm × 250 m)	● ^{*11}	-
	Reeving Winch cum Hydraulic Tagline	● ^{*11}	-
	for Hydraulic Tagline (6 × Fi (29) ϕ 10 mm × 45 m) for Reeving (6 × Fi (29) ϕ 10 mm × 160 m)		
	Reduction Counterweight Specification	● ^{*12}	-
	Sling Ropes for Disassembly and Assembly (for Counterweights, Crawlers)	●	●
	Air Cleaner Double Element	○	○
	Additional Fuel Filter (Triple Filter)	●	●
Additional Spare Parts (Hydraulic Oil Filter)	●	●	
Additional Tools (Large Hammer, Crowbar, Chisel)	●	●	
Other	Standard Supplied Tools	○	○
	Standard Spare Parts	○	○

*1 Optional for the flat shoes.

*2 Europe specification machines only.

*3 Cannot be installed at the same time.

*4 Cannot be equipped when the cross operation lever or front operation lever is installed.

*5 Used for opening/closing rope. Length is 69 m.

*6 Used for supporting rope. Length is 62 m.

*7 An operation lever lock is not attached to the front, rear or hoist when the cross operation lever is installed.

*8 Europe specification machines only.

*9 3200mm width cast type counter weight only.

*10 When it chooses, the width at the time of transportation is set to not less than 3.2 m.

*11 (1) Hydraulic tagline (maximum line pull: 2.9 kN (300 kg))

(2) Reeving winch unit (maximum line pull: 11.8 kN (1,200 kg))

(3) Reeving winch and hydraulic tagline (maximum line pull: 2.9 kN(300kg))

*12 The reduction counterweight specification can only be used for the crane specification, with the exception of the crane jib.

A series of horizontal dashed lines for writing.

- We are constantly improving our products and therefore reserve the right to change designs and specifications without notice.
- Units in this specification are shown under International System of Units; the figures in parenthesis are under Gravitational System of Units as old one.

Hitachi Sumitomo Heavy Industries Construction Crane Co.,Ltd.

9-3, Higashi-Ueno 6-chome, Taito-ku, Tokyo 110-0015, Japan
Phone: 81-3-3845-1387 Facsimile: 81-3-3845-1394

<http://www.hsc-crane.com>